

36 V, 600 mA Buck Converter

Features

- Qualified for Automotive Applications
- AEC-Q100 Qualified with the Following Results:
 - . Device Temperature Grade 1: -40 °C to 125 °C
- Ambient Operating Temperature Range
 - . Device HBM ESD Classification Level H1C
 - . Device CDM ESD Classification Level C4A
- 4 V to 36 V Input Range
- 600 mA Continuous Output Current
- Integrated Synchronous Rectification
- Current Mode Control
- Minimum Switch-On Time: 60 ns
- Internal Compensation for Ease of Use
- 400 kHz Switching Frequency with PFM Mode (Option 800 kHz, 1.2 MHz, 1.6 MHz, 2 MHz, 2.4 MHz)
- Frequency Synchronization to External Clock
- 75 μ A Quiescent Current at No Load
- Soft-Start into a Pre-Biased Load
- High Duty Cycle Operation Supported
- Output Short-Circuit Protection with Hiccup Mode Protections

Applications

- Automotive Battery Regulation
- Industrial Power Supplies
- Telecom and Datacom Systems
- General Purpose Wide Vin Regulation

Description

The SM6003 is an easy to use 36 V and 600 mA synchronous step-down regulator. With a wide input range from 4 V to 36 V, it is suitable for various applications from industrial to automotive for power conditioning from unregulated sources. Peak current mode control is employed to achieve simple control loop compensation and cycle-by-cycle current limiting, and a quiescent current of 75 μ A makes it suitable for battery powered systems. The internal loop compensation means that the user is free from the tedious task of loop compensation design, and this also minimizes the need for external components. In addition, the precision enable input allows simplification of regulator control and system power sequencing. Protection features include cycle-by-cycle current limit, hiccup mode short circuit protection and thermal shutdown due to excessive power dissipation.

Device Information

Part	Package	Size
SM6003	8 DFN	3 mm x 3 mm

Simplified Block Diagram

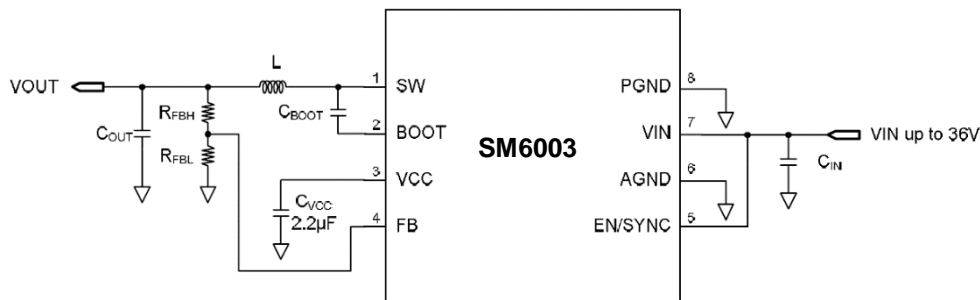

Silicon Mitus cannot assume any responsibility for the consequence of use of information furnished nor for any infringement of patents or other rights of third parties which may result from its use. No Circuit patent licenses are implied. Silicon Mitus reserves the right to change the circuitry and specifications without notice at any time. This publication supersedes and replaces all information previously supplied. Silicon Mitus products are not authorized for use as critical components in life support devices or systems without the express written approval of Silicon Mitus.

© 2017 Silicon Mitus, Inc. - Printed in Korea - All Rights Reserved