

A Very High Efficiency Switched Capacitor 6A Charger with Quadruple Mode

Features

- Highly Integrated Switched Capacitor Charger with a Quadruple mode
 - Maximum 6A Charging Current at 2:1 forward mode
 - Maximum 5A Charging Current at 1:1 forward mode
 - Maximum 2.25A IBUS Current at 1:2 reverse mode
 - Maximum 4.5A IBUS Current at 1:1 reverse mode
- 97% Efficiency at VBAT=4.4V and IBAT=5A at 2:1 mode
- Embedded Infinite Regulation Loop with an internal Q_{RB} Switch
 - IBUS Input Current Regulation
 - VBAT Output Voltage Regulation
 - IBAT Output Current Regulation
- Very Accurate 6-Channel ADC with 12-Bit Resolution
 - VBUS Input Voltage with 4mV Resolution
 - IBUS Input Current with 2mA Resolution
 - VBAT Output Voltage with 2mV Resolution
 - IBAT Output Current with 2mA Resolution
 - THEM Temperature with 8mV Resolution
 - Die Temperature with 1°C Resolution
- Smart Protections
 - Programmable Input/Output Over-Voltage Protection
 - Programmable Input/Output Over-Current Protection
 - Programmable Input Under-Current Protection
 - Flying Capacitor Short Protection
 - Die Thermal Shutdown
 - Watchdog Timer
- Up to 1MHz Fast-mode Plus I²C Interface
- 42-Bump, 2.9 mm x 2.75 mm WLCSP Package

Applications

- Smartphones, Tablet PC, and Portable Devices

Description

The SM5451 is a highly integrated quadruple-mode switched capacitor charger that integrates an infinite regulation loop and a very accurate 12-Bit ADC. The device features not only a switched-capacitor architecture for a current doubler mode but also a path-through topology for a bypass mode.

This very high efficiency switched capacitor charger with a very low R_{DS_ON} resistance reduces the thermal dissipation of a fast charging system, which results in shorter charging time. The device integrates a stand-alone infinite regulation loop for IBUS, VBAT and IBAT using an internal Q_{RB} switch.

The device also includes a very accurate 12-bit ADC to provide input voltage, input current, output voltage, output current, THEM pin and die temperature needed to manage the charging profile of fast charging system.

The device integrated powerful protection schemes such as over-voltage, over-current, under-current, over-temperature, a flying capacitor short-circuit and a watchdog timer to secure a robust charging for the system.

The SM5451 is available in 2.9 mm x 2.75 mm, 42-bumps WLCSP package.

Device Information

Part	Package	Size
SM5451	42-Bump WLCSP 0.4 mm Pitch	2.9mm x 2.75mm

Simplified Block Diagram

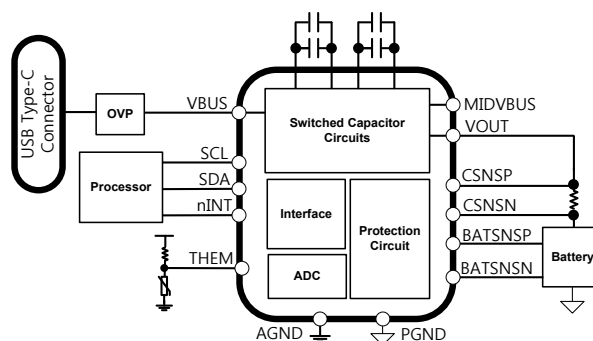

SM5451

Silicon Mitus cannot assume any responsibility for the consequence of use of information furnished nor for any infringement of patents or other rights of third parties which may result from its use. No Circuit patent licenses are implied. Silicon Mitus reserves the right to change the circuitry and specifications without notice at any time. This publication supersedes and replaces all information previously supplied. Silicon Mitus products are not authorized for use as critical components in life support devices or systems without the express written approval of Silicon Mitus.

© 2021 Silicon Mitus, Inc. - Printed in Korea - All Rights Reserved

CONFIDENTIAL
SUBJECT TO CHANGE W/O NOTICE